

NOTES:

- USE PRESSURE TREATED LUMBER THAT MEETS LOCAL ENVIRONMENTAL STANDARDS
- EQUIPMENT LIST:
 - (6) 3X6X60"
 - (2) 3X6X120"
 - (2) 2"X2'X8' RIGID FOAM INSUL
 - SHIMS (AS NEEDED)

PROFILE

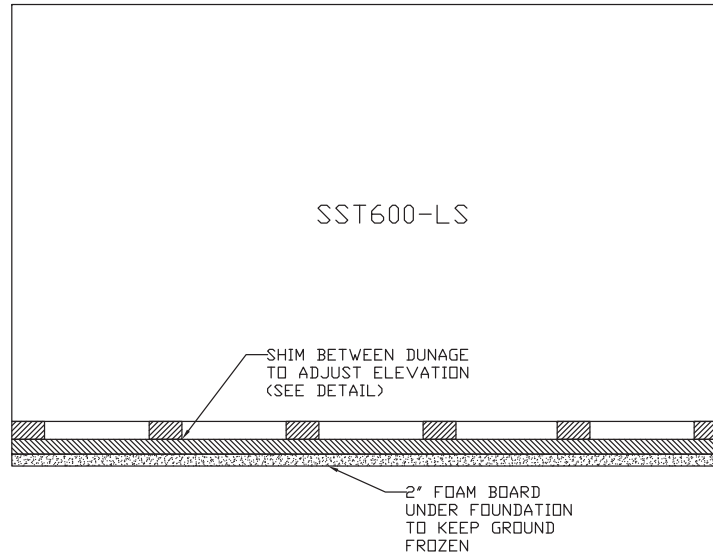

PLAN VIEW

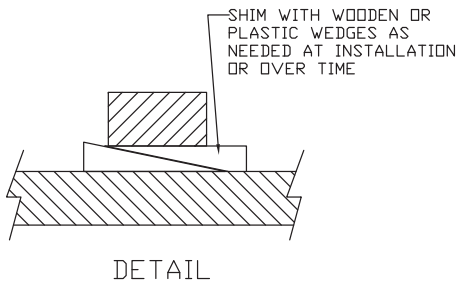
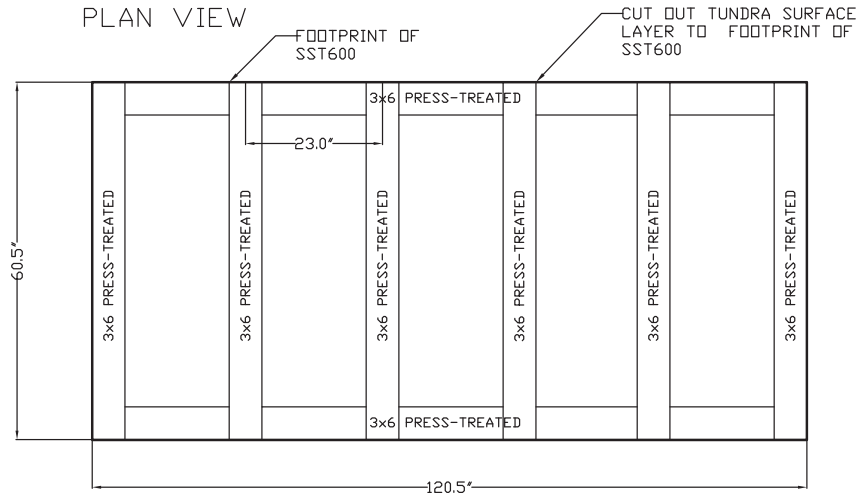

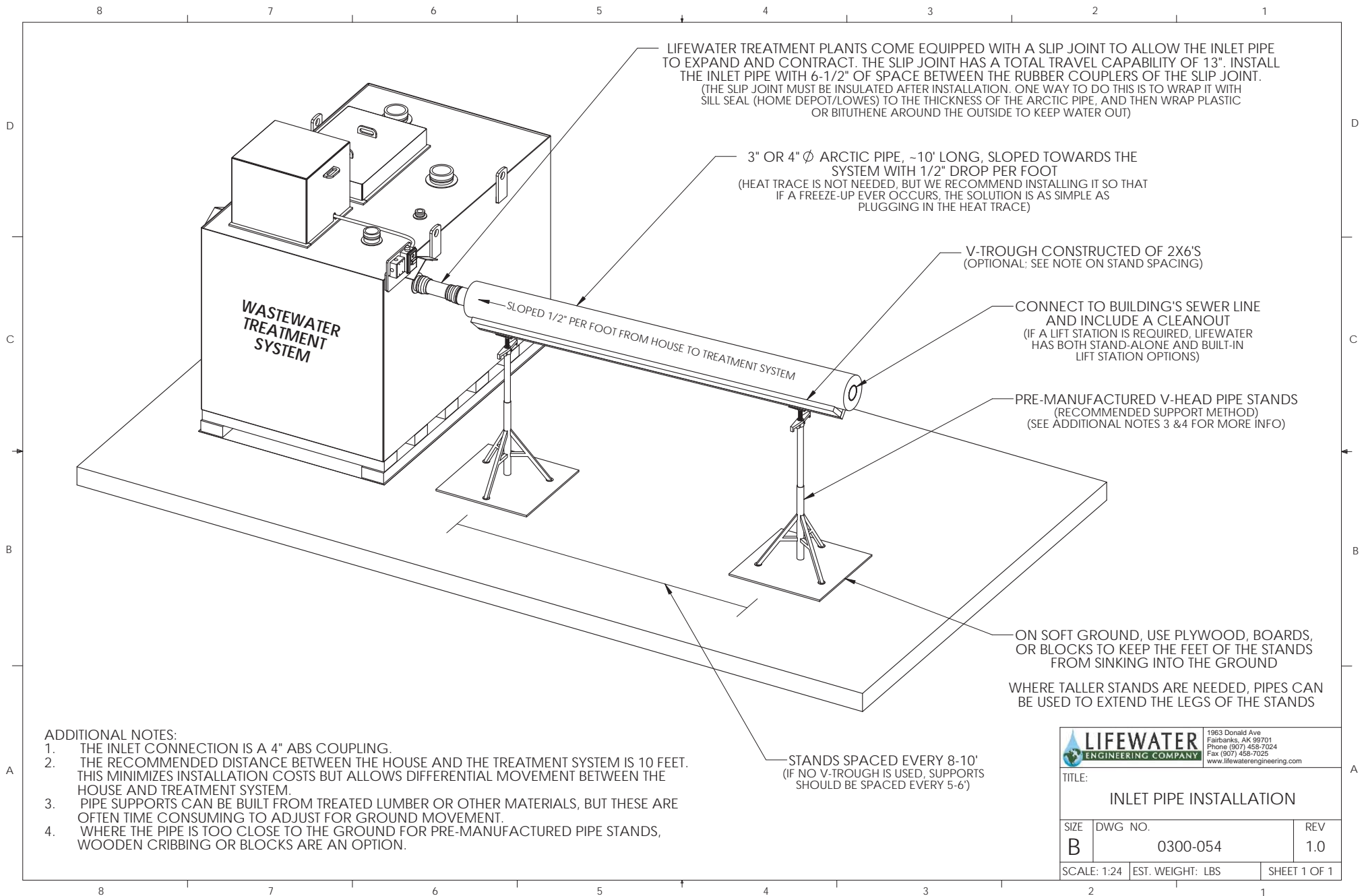

LIFEWATER TREATMENT PLANTS COME EQUIPPED WITH A SLIP JOINT TO ALLOW THE INLET PIPE TO EXPAND AND CONTRACT. THE SLIP JOINT HAS A TOTAL TRAVEL CAPABILITY OF 13". INSTALL THE INLET PIPE WITH 6-1/2" OF SPACE BETWEEN THE RUBBER COUPLERS OF THE SLIP JOINT. (THE SLIP JOINT MUST BE INSULATED AFTER INSTALLATION. ONE WAY TO DO THIS IS TO WRAP IT WITH SILL SEAL (HOME DEPOT/LOWES) TO THE THICKNESS OF THE ARCTIC PIPE, AND THEN WRAP PLASTIC OR BITUTHENE AROUND THE OUTSIDE TO KEEP WATER OUT)

3" OR 4" Ø ARCTIC PIPE, ~10' LONG, SLOPED TOWARDS THE SYSTEM WITH 1/2" DROP PER FOOT (HEAT TRACE IS NOT NEEDED, BUT WE RECOMMEND INSTALLING IT SO THAT IF A FREEZE-UP EVER OCCURS, THE SOLUTION IS AS SIMPLE AS PLUGGING IN THE HEAT TRACE)

V-TROUGH CONSTRUCTED OF 2X6'S (OPTIONAL: SEE NOTE ON STAND SPACING)

CONNECT TO BUILDING'S SEWER LINE AND INCLUDE A CLEANOUT (IF A LIFT STATION IS REQUIRED, LIFEWATER HAS BOTH STAND-ALONE AND BUILT-IN LIFT STATION OPTIONS)

PRE-MANUFACTURED V-HEAD PIPE STANDS (RECOMMENDED SUPPORT METHOD) (SEE ADDITIONAL NOTES 3 & 4 FOR MORE INFO)

ON SOFT GROUND, USE PLYWOOD, BOARDS, OR BLOCKS TO KEEP THE FEET OF THE STANDS FROM SINKING INTO THE GROUND

WHERE TALLER STANDS ARE NEEDED, PIPES CAN BE USED TO EXTEND THE LEGS OF THE STANDS

STANDS SPACED EVERY 8-10' (IF NO V-TROUGH IS USED, SUPPORTS SHOULD BE SPACED EVERY 5-6')

ADDITIONAL NOTES:

1. THE INLET CONNECTION IS A 4" ABS COUPLING.
2. THE RECOMMENDED DISTANCE BETWEEN THE HOUSE AND THE TREATMENT SYSTEM IS 10 FEET. THIS MINIMIZES INSTALLATION COSTS BUT ALLOWS DIFFERENTIAL MOVEMENT BETWEEN THE HOUSE AND TREATMENT SYSTEM.
3. PIPE SUPPORTS CAN BE BUILT FROM TREATED LUMBER OR OTHER MATERIALS, BUT THESE ARE OFTEN TIME CONSUMING TO ADJUST FOR GROUND MOVEMENT.
4. WHERE THE PIPE IS TOO CLOSE TO THE GROUND FOR PRE-MANUFACTURED PIPE STANDS, WOODEN CRIBBING OR BLOCKS ARE AN OPTION.

		1963 Donald Ave Fairbanks, AK 99701 Phone (907) 458-7024 Fax (907) 458-7025 www.lifewaterengineering.com
TITLE:		
INLET PIPE INSTALLATION		
SIZE	DWG. NO.	REV
B	0300-054	1.0
SCALE: 1:24	EST. WEIGHT: LBS	SHEET 1 OF 1

8 7 6 5 4 3 2 1

D

D

C

C

B

B

A

A

INSULATE ALL EXPOSED PIPE CONNECTIONS

ANCHOR THE PIPE TO THE PROVIDED BRACKETS ON THE TREATMENT SYSTEM (THIS PREVENTS THE PIPE FROM "WALKING" AWAY FROM THE TANK AS THE PIPE EXPANDS AND CONTRACTS)

PRE-MANUFACTURED V-HEAD PIPE STANDS (RECOMMENDED SUPPORT METHOD) (ALTHOUGH MORE EXPENSIVE THAN BUILDING WOODEN SUPPORTS, PIPE STANDS ARE MUCH EASIER TO ADJUST TO COMPENSATE FOR GROUND MOVEMENT)

4" Ø ARCTIC PIPE, AT LEAST 20' LONG (HEAT TRACE IS NOT NEEDED, BUT WE HIGHLY RECOMMEND INSTALLING IT SO THAT IF A FREEZE-UP EVER OCCURS, THE SOLUTION IS AS SIMPLE AS PLUGGING IN THE HEAT TRACE)

V-TROUGH CONSTRUCTED OF 2X6'S (OPTIONAL: SEE NOTE ON STAND SPACING)

END OF PIPE SHOULD BE AT LEAST 12" OFF THE GROUND

WOODEN SPLASH PLATE (PREVENTS EROSION AT DISCHARGE)

STANDS SPACED EVERY 8-10' (IF NO V-TROUGH IS USED, SUPPORTS SHOULD BE SPACED EVERY 5-6')

ON SOFT GROUND, USE PLYWOOD, BOARDS, OR BLOCKS TO KEEP THE FEET OF THE STANDS FROM SINKING INTO THE GROUND

USE WOODEN CRIBBING OR BLOCKS TO SUPPORT THE PIPE WHEN IT IS CLOSE TO THE GROUND (ALTERNATE SUPPORT METHOD)

ADDITIONAL NOTES:

1. THE OUTLET OF THE TREATMENT SYSTEM IS 1-1/2" PVC. THE CONNECTION TO THE EFFLUENT PIPE IS BEST MADE WITH A FLEXIBLE RUBBER COUPLING SINCE THE EFFLUENT PIPE AND/OR THE TREATMENT SYSTEM WILL MOVE OVER TIME.
2. ELBOWS AND OTHER FITTINGS CAN BE USED TO DIRECT THE OUTLET PIPE IN ANY DESIRED DIRECTION. SEE "EFFLUENT PIPE SWING JOINT" DRAWING.
3. THE EFFLUENT PUMP HAS A MAXIMUM HEAD OF 15 FEET.
4. CONTACT LIFEWATER ENGINEERING FOR ADDITIONAL OPTIONS.

		1963 Donald Ave Fairbanks, AK 99701 Phone (907) 458-7024 Fax (907) 458-7025 www.lifewaterengineering.com
TITLE:		
EFFLUENT PIPE INSTALLATION		
SIZE	DWG. NO.	REV
B	0300-055	1.0
SCALE: 1:36	EST. WEIGHT: LBS	SHEET 1 OF 1

8 7 6 5 4 3 2 1

NOTE: THIS SWING JOINT IS ONLY NEEDED WHEN THE PIPE MUST LEAVE THE SYSTEM AT AN ANGLE OR NEEDS TO BE RAISED OR LOWERED. IF THE EFFLUENT PIPE CAN RUN STRAIGHT OUT FROM THE SYSTEM, THEN THE BUSHING AND RUBBER COUPLER (UNDERLINED BELOW) CAN BE USED TO CONNECT DIRECTLY TO THE SYSTEM.

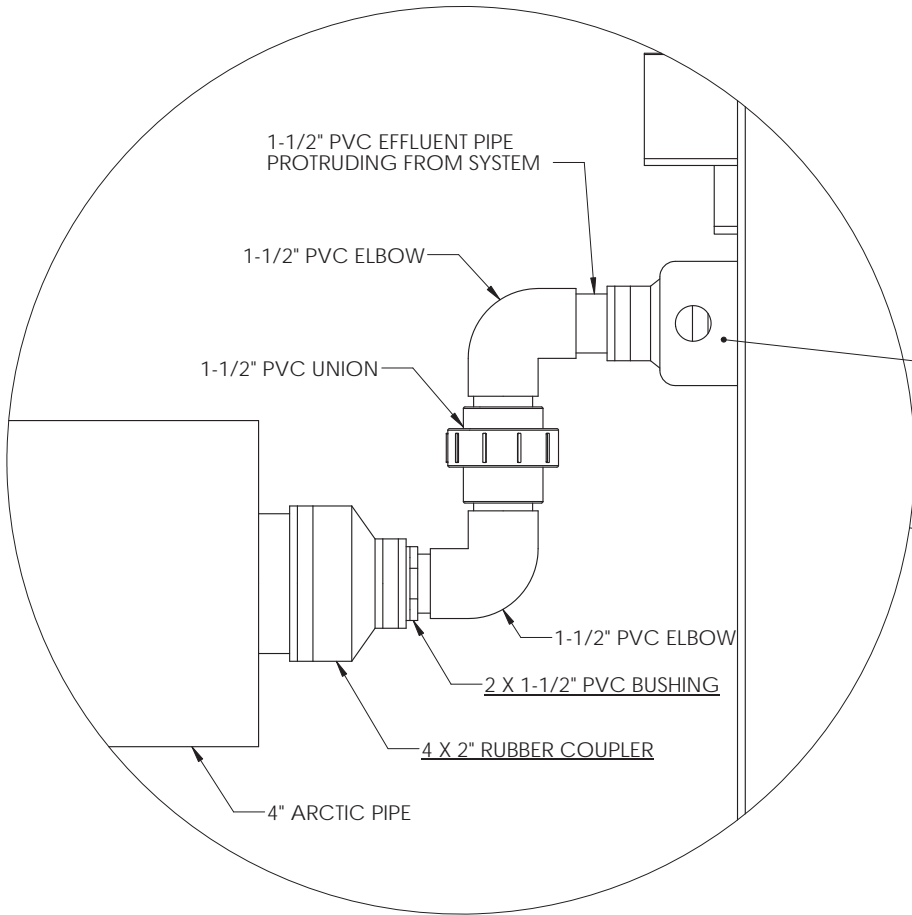

DETAIL A
SCALE 1 : 4

ROTATE THE LOWER ELBOW TO POINT THE EFFLUENT PIPE IN THE DESIRED DIRECTION

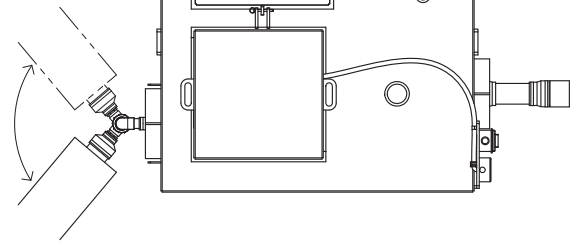

SIDE VIEW

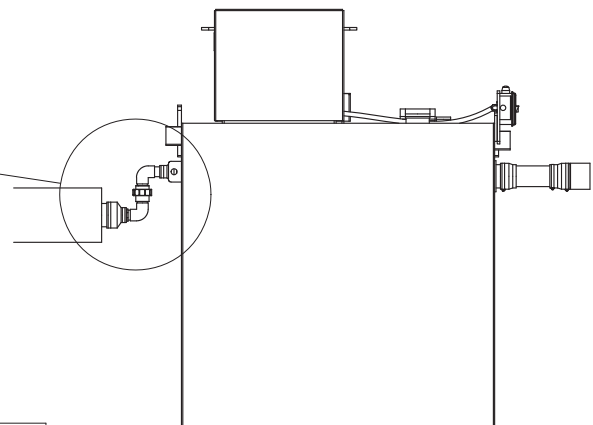

THE EFFLUENT PIPE SHOULD BE TIED TO THE BRACKETS ON THE SYSTEM TO PREVENT THE PIPE FROM PULLING AWAY AND/OR BREAKING THE FITTINGS

THE SAME FITTINGS CAN BE USED TO RAISE OR OFFSET THE EFFLUENT LINE IF AN INSTALLATION REQUIRES IT. THE EFFLUENT PUMP HAS A MAXIMUM HEAD OF 15 FT.

	1963 Donald Ave Fairbanks, AK 99701 Phone (907) 458-7024 Fax (907) 458-7025 www.lifewaterengineering.com

TITLE:
EFFLUENT PIPE SWING JOINT

SIZE B	DWG. NO. 0300-056	REV 1.0
------------------	----------------------	------------

SCALE: 1:24	EST. WEIGHT: LBS	SHEET 1 OF 1
-------------	------------------	--------------