



## Model SST600 ExtremeSTP® Sustainable Sewage Treatment Plant

---

**This energy efficient, sustainable sewage treatment plant** for use in rural Alaska villages was developed by Lifewater Engineering Company in cooperation with the Cold Climate Housing Research Center and the Denali Commission. Beginning in November 2009, Lifewater re-engineered our standard residential treatment plant to reduce its electrical consumption. The result is this new model that uses 1/3 the electrical power of other residential systems. This treatment plant is a good choice for your home, whether you are on municipal power or alternative energy.



### Treatment Technology:

Fixed activated sludge treatment is powerful yet simple to operate and maintain. Wastewater is pretreated using a settling compartment. Then aerobic bacteria oxidize the BOD<sub>5</sub> and COD, and ultraviolet light disinfects the treated water. Clean water is stored in a third compartment until it is discharged to the ground surface by an effluent pump.

### Standard Features:

- Indoor and outdoor configurations
- Suitable for up to a 4-bedroom home or up to 8 persons
- 'Plug-and-play' design makes installation simple and service easy
- System is optimized for energy efficiency
- Heavy duty, non-corrodible, plastic tank
- Outdoor model is fully insulated for year around use anywhere in Alaska or Canada
- Indoor model is totally sealed and set for easy venting to the outdoors
- Effluent pump prevents icing at the point of discharge
- UV disinfection
- Includes automatic air cleaning cycle
- Residential systems come with a 2-year warranty and 2-year service contract (in the Fairbanks/North Pole area)
- Sized for air-transport to remote communities

## Outdoor SST600: Dimensions

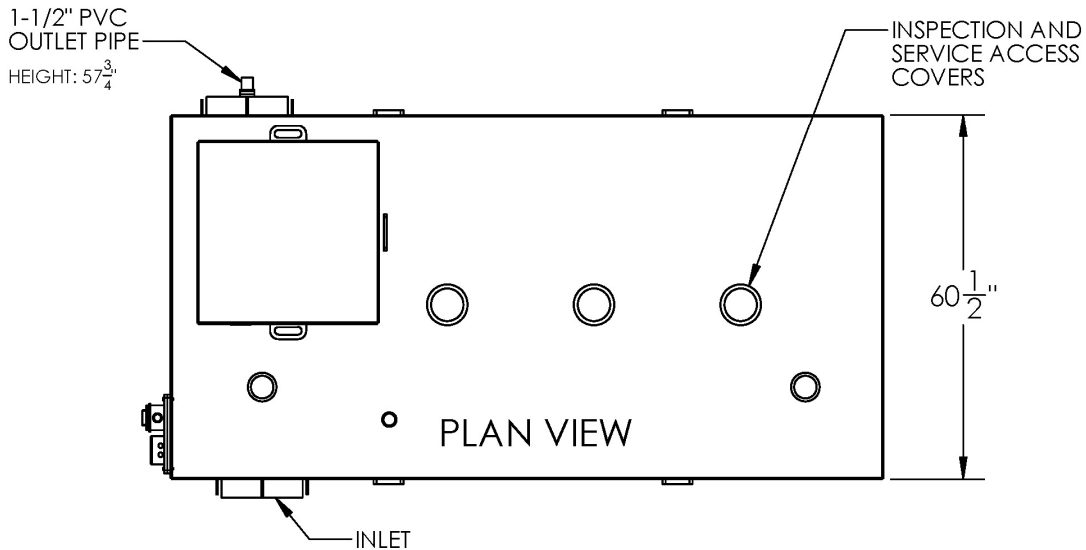
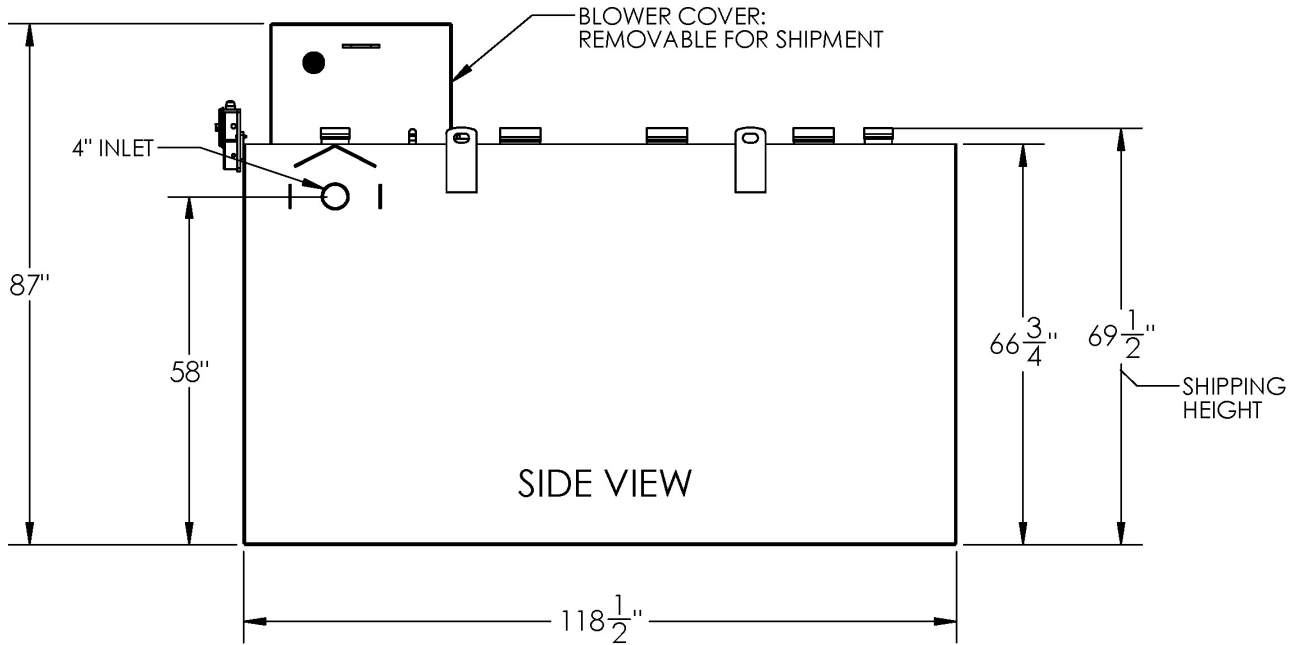

Shipping weight: ~1,300 lbs  
Shipping dimensions: 70"W x 119"L x 69.5"H